

# T Series 77 – 20 mm bore

**GENERAL PUMP** *A member of the Interpump Group*

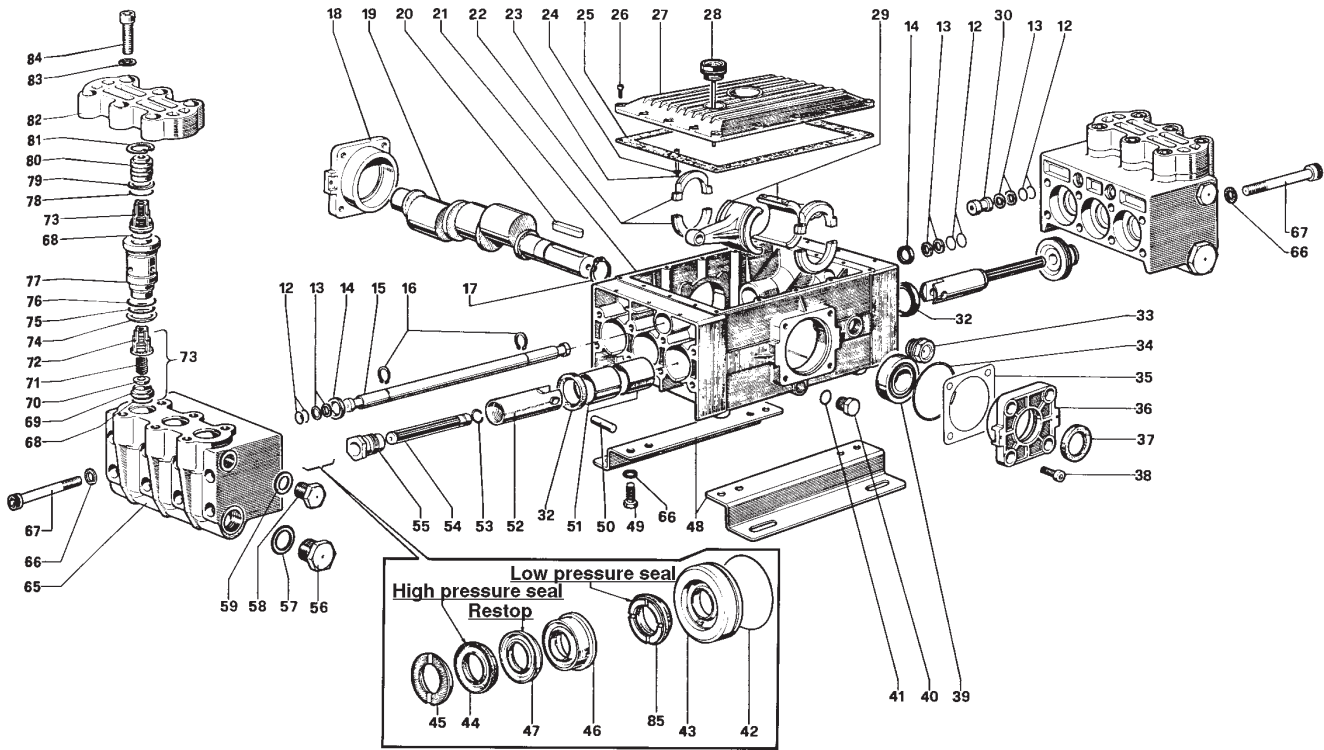

## PARTS LIST

ITEM PART NO.	DESCRIPTION	KIT NO.	QTY.	ITEM PART NO.	DESCRIPTION	KIT NO.	QTY.	ITEM PART NO.	DESCRIPTION	KIT NO.	QTY.	
12.	90.3835.00	O-Ring	8	35.	76.2200.78	Shim	2	58.	98.2178.00	Cap	3	
13.	90.5090.00	Anti-Ext. Ring	8	36.	76.1500.22	Cover	1	59.	96.7514.00	Washer	3	
14.	90.1614.00	Ring	4	37.	90.1672.00	Ring	32	65.	62.1202.41	Manifold	2	
15.	62.2123.92	Connect. Tube	1	38.	99.3652.00	Screw	8	66.	96.7195.00	Washer	20	
16.	90.0605.00	Cir-Clip	2	39.	91.8474.00	Bearing	2	67.	99.4465.00	Screw	16	
17.	90.0695.00	Cir-Clip	1	40.	98.2100.00	Cap	1	68.	90.3850.00	O-Ring	122	
18.	76.1501.22	Cover	1	41.	90.3833.00	O-Ring	1	69.	36.2024.66	Valve Seat	122	
19.	76.0210.35	Crankshaft	1	42.	90.3903.00	O-Ring	76, 78	70.	36.2013.66	Valve	122	
20.	91.4978.00	Key	1	43.	61.0800.70	Packing Retainer	76, 78	71.	94.7394.00	Spring	122	
21.	77.0100.22	Crankcase	1	44.	90.2705.00	Packing	77, 78	72.	36.2023.51	Valve Guide	122	
22.	77.2120.01	Holding Ring	6	45.	47.1000.51	Head Ring	7, 78	73.	36.7114.01	Valve Assy.	122	
23.	99.1927.00	Screw	12	46.	61.2160.70	Intermed. Ring	75, 78	74.	90.5181.00	Anti-Ext. Ring	6	
24.	96.6938.00	Washer	12	47.	90.2709.00	Ring	77, 78	75.	90.4057.00	O-Ring	6	
25.	77.2118.84	Gasket	1	48.	76.2000.74	Foot	2	76.	90.3871.00	O-Ring	6	
26.	99.1867.00	Screw	16	49.	99.4266.00	Screw	4	77.	61.2177.66	Bushing	6	
27.	77.2114.22	Cover	1	50.	97.7400.00	Plunger Pin	6	78.	90.3855.00	O-Ring	6	
28.	98.2272.00	Oil Dip Stick	1	51.	90.9172.00	Bushing	12	79.	90.5154.00	Anti-Ext. Ring	3	
29.	77.0302.41	Connect. Rod	3	52.	61.0500.66	Plunger Guide	6	80.	61.2176.70	Cap	6	
30.	62.2130.70	Cap	2	53.	90.0115.00	Cir-Clip	6	81.	90.0670.00	Cir Clip	6	
32.	90.1670.00	O-Ring	44	54.	61.0400.56	Plunger (20 mm)	6	82.	61.2182.41	Valve Cover	2	
33.	97.5968.00	Oil Indicator	1	55.	61.2195.66	Plunger Screw	6	83.	96.7300.00	Washer	12	
34.	90.4141.00	O-Ring	2	56.	98.2325.00	Cap	2	84.	99.4860.00	Screw	12	
				57.	96.7870.00	Washer	2	85.	90.2710.00	Seal, Low Press., 20mm	77, 78	6

## REPAIR KITS

KIT NO.	7	32	44	75	76	77	78	122
ITEM NO.s INCLUDED IN KIT	45	37	32	46	42, 43	44, 47, 85	42, 43, 44, 45, 46, 47, 85	68, 69, 70, 71, 72 (73)
NUMBER OF ASSEMBLIES IN KIT	6	2	3	3	3	3	1	6
NUMBER OF CYLINDERS KIT WILL SERVICE	3	-	3	3	3	3	1	3

## TORQUE SPECS\*

Position	Ft.-lbs.
23	8.8
26	7.3
33	13.2
38	13.2
40	29.4
49	29.4
55	81.0
58	36.8
67	51.5
84	95.8

